

PSB

氣壓塊狀轉角缸

PSB PNEUMATIC SWING CLAMP

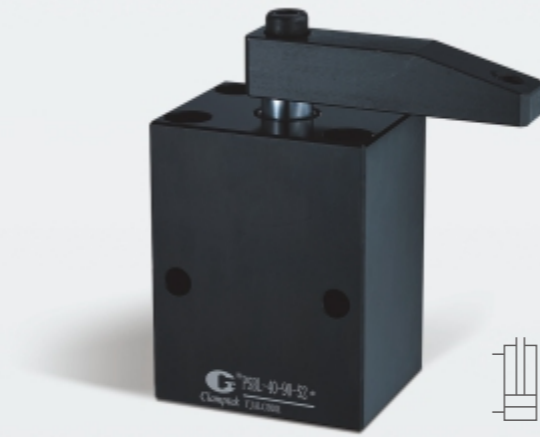

產品特性

設計簡單，結構緊湊，重量輕，壽命長以及高的夾持力使它成為一種好的夾具。本產品有可加裝感應器。可任意選擇上面和下面及側面安裝。

最大操作壓力：7 kgf/cm²
 最小操作壓力：4 kgf/cm²
 作動方式：複動式

FEATURES

Simple and compact structure, lightweight, high clamping capacity, and long product lifespan. This product can be equipped with sensor switches with the option to install on the top, bottom or on the side.

Max. operating pressure: 7 kgf/cm²
 Min. operating pressure: 4 kgf/cm²
 Double acting

剖面圖 Sectional view

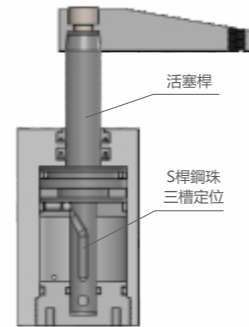

注意事項

夾緊及放鬆作動速度需適當放緩。特殊壓臂長度及重量不得超過標準壓臂的1.5倍。壓臂旋轉示意圖及安裝拆卸方式，請參見第4頁。

NOTE

The speed of clamping and unclamping action needs to be slowed down appropriately. The length and weight of the customized clamping arm shall not exceed 1.5 times of the standard clamping arm. Please refer to page 4 for the rotation diagram, installation instruction and removal methods of the clamping arm.

訂購標示法 ORDERING INDICATION

示例：PSBL-40-90-S1

PSB	系列 Series	PSB
L	轉角方向 Rotating direction	右轉R或左轉L Turn right or turn left
40	氣缸內徑 Cylinder inside diameter	Φ25, Φ32, Φ40, Φ50, Φ63
90	轉角角度 Rotating angle	標準角度 Standard angle 90° (±2°) 訂做角度 Order angle 0°, 45° (±2°), 60° (±2°)
S1	感應開關 Sensor switch	S1: 1個 S1:1 pc of S1 S2: 2個 S2:2 pcs of S2

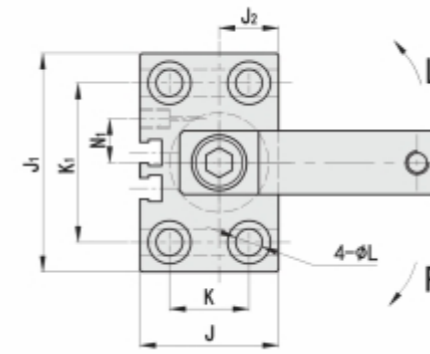

- Ⓐ 夾持氣孔 Clamping port
- Ⓑ 放鬆氣孔 Unclamping port

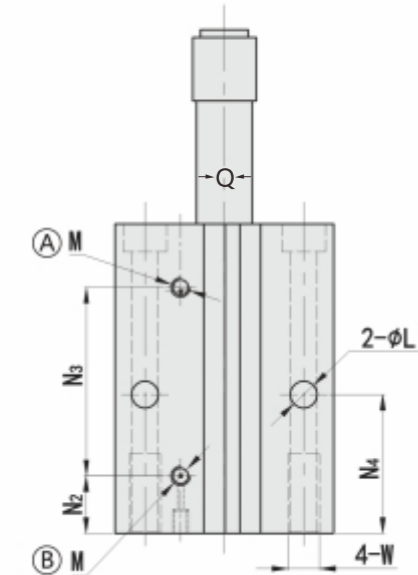
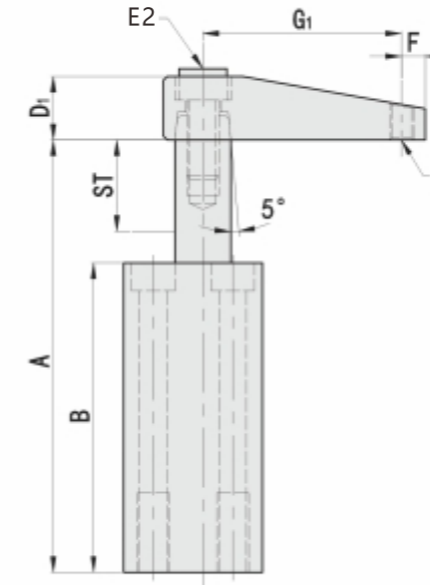

規格參數表 SPECIFICATIONS

型號	理論夾持力 (7kgf/cm ²)	轉角行程	夾緊行程	總行程	拉入容積	推出容積	拉入受壓面積	推出受壓面積	使用溫度範圍	使用流體
MODEL	CLAMPING FORCE AT 7kgf/cm ² (kgf)	Swing stroke (mm)	CLAMPING STROKE (mm)	TOTAL STROKE (mm)	CYLINDER CAPACITY CLAMP (cm ³)	CYLINDER CAPACITY UNCLAMP (cm ³)	EFF.PISTON AREA CLAMP (cm ²)	EFF.PISTON AREA UNCLAMP (cm ²)	RANGE OF TEMPERATURE (°C)	USABLE FLUID
PSB-25	24	13	14	27	9.10	13.26	3.37	4.91	-10~+60°C	過濾之乾燥壓縮空氣 Filtered dry compressed air
PSB-32	42	16	14	30	18.06	24.12	6.02	8.04	-10~+60°C	
PSB-40	74	15	15	30	31.68	37.68	10.56	12.56	-10~+60°C	
PSB-50	116	17	15	32	52.80	62.82	16.5	19.63	-10~+60°C	
PSB-63	196	15	15	30	84.06	93.48	28.02	31.16	-10~+60°C	

Unit:mm

MODEL	ST:Swing /Clamping	A:鬆開狀態 /Unclamp	B	D1	E1	E2	F	G1	J	J1	J2	K	K1	N1	N2	N3	N4	L	L'	M	W	Q
PSB-25	27:13/14	109	78	□16	M6	M8	6	50	35	55	15	20	40	11	14.5	47.5	35	Φ6.8-Φ11×7D	Φ6.8	M5	M8×20D	Φ14
PSB-32	30:16/14	126	90	□19	M8	M8	9	60	45	60	20	30	45	12	21	51.5	45	Φ6.8-Φ11×7D	Φ6.8	PT1/8	M8×25D	Φ16
PSB-40	30:15/15	126	90	□19	M8	M8	9	70	55	70	25	37	52	15	22	49	40	Φ8.5-Φ14×9D	Φ8.5	PT1/8	M10×20D	Φ16
PSB-50	32:17/15	137	100	□25	M12	M10	10	80	65	85	30	46	66	17.5	25	53.5	40	Φ8.5-Φ14×9D	Φ8.5	PT1/8	M10×30D	Φ20
PSB-63	30:15/15	137	100	□25	M12	M10	10	90	80	100	37.5	60	80	18	20.5	56.5	35	Φ10.5-Φ16.5×10.5D	Φ10.5	PT1/8	M12×25D	Φ20